

Radiant Heaters

Radiant Heaters	Sheath Materials	Max. Operating Temperatures		Typical Max. Watt Densities		Page
		°F	°C	W/in ²	W/cm ²	
RAYMAX® Panel	Stainless steel/ Alumized steel	2000	1095	30	4.7	513
Mineral Insulated (MI) Band and Strip Emitters	Stainless steel	1300	700	30	4.7	527



Radiant Heaters



Radiant Heaters

RAYMAX® Panel Heaters

The RAYMAX® radiant panel heater product line from Watlow® solves virtually any application requiring radiant heat from contamination-resistant surfaces to fast responding high-temperature panels.

Watlow's engineering staff has the training and expertise required to meet the most complicated application requirements. Technical support includes calculating watt density and temperature requirements and recommending system components such as sensors and controllers.

Performance Capabilities

- Maximum face temperature up to 2000°F (1095°C)
- Maximum watt densities up to 30 W/in² (4.7 W/cm²)

Features and Benefits

Variety of styles

- Match the ideal temperature and watt density requirements of the application

Watlow engineering and application support

- Assures projects run smoothly

Custom designs

- Adapts to specific needs

Watlow sensors and controllers are compatible with RAYMAX heaters

- Offers a single-source thermal system that is reliable and designed for your application



Typical Applications

- Thermoforming
- Food warming
- Paint and epoxy curing
- Heat treating
- High-temperature furnaces
- Tempering and annealing processes



Caution: Fire Hazard

Radiant heaters must not be operated in the presence of flammable vapors, gases or combustible materials without proper ventilation and safety precautions. Radiant heaters must be properly wired and controlled to comply with all applicable electrical codes.

Radiant Heaters

RAYMAX Panel Heaters

RAYMAX 1010

Designed to resist contamination, the RAYMAX 1010 is ideal for use in screen printing, food warming and other low-heat applications. The heater's "sealed face" keeps contaminants away from the heating element, and the metal surface can be easily wiped or brushed clean whenever needed.

Rugged, all-metal construction creates a shock-proof, shatter-proof heater, which is durable and long lasting.

Performance Capabilities

- Face temperature: 1000°F (540°C) maximum
- Watt densities: 10 W/in² (1.5 W/cm²) maximum
- 50 amperes maximum
- Maximum voltage up to 480V

Features and Benefits

Uniform full-surface heat source

- Provides more even heat

Convenient ready-to-use package

- Makes installation easier

One-inch thick backside insulation

- Reduces losses

Totally sealed version available

- Suitable for hose down applications

Repeatable temperature sensing options

- Increases accuracy

UL® component recognized versions are available

Typical Applications

- Drying screen-printed textiles
- Curing process coatings on circuit boards
- Food warming/cooking
- Epoxy curing
- Thermoforming

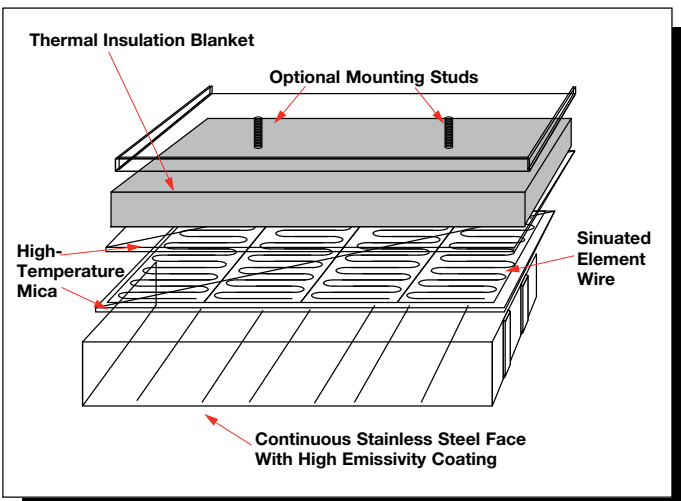

Radiant Heaters

RAYMAX Panel Heaters

RAYMAX 1010

Applications and Technical Data

Sizes and Ratings

Thickness: 1³/₄ in. (45 mm)

Voltage: Customer specified up to 480V.

Note: Small heaters may not be able to be built at high voltages. Contact your Watlow representative for specific application requirements.

Watt density: Up to 10 W/in² (1.5 W/cm²), 50A max.

Face temperature: Up to 1000°F (540°C)

Typical peak energy wavelength: 3.5-4 microns

Note: New designs require a minimum charge per design.

Specifications

Heater Dimensions	Min.	Max.	Increments
Width: in. (mm)	4 (102)	20 (508)	2 (50.8)
Length: in. (mm)	10 (254)	68 (1727)	0.06 (1.6)
Area: in ² (cm ²)		864 (5574)	Any

Note: Less than maximum length x width may exceed the maximum area.

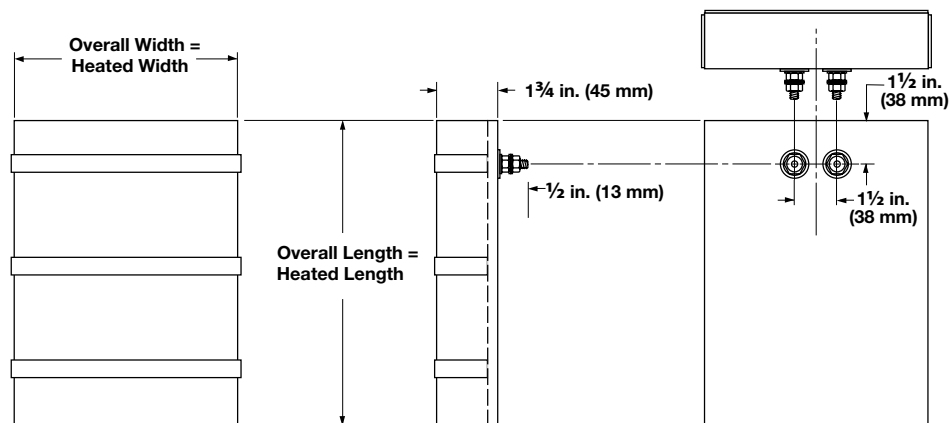

Options

- Terminal box
- Thermowell (VAT style thermocouple required)
- Thermocouple pocket (thermocouple required)
- Thermocouple welded to hot face
- Mounting studs
- Zoning
- Totally sealed construction
- Food-safe surface treatment

Radiant Heaters

RAYMAX Panel Heaters

RAYMAX 1120

The RAYMAX 1120 radiant heater panel is lightweight, yet sturdy and durable. The emitter sheath is stainless steel with a black coating providing a highly efficient radiating surface. The heater's low mass allows rapid start-up and fast response to controllers.

The patented RAYMAX heater features 1 in. (25 mm) wide emitter strips which are individually replaceable for lower maintenance costs. Weighing only 5.5 lbs/ft² (26.8 kg/m²), the heater is easy to mount.

Performance Capabilities

- Face temperature: 1100°F (595°C) maximum
- Watt density: 20 W/in² (3 W/cm²) maximum
- Maximum voltage up to 480V
- UL® component recognized versions are available

Features and Benefits

Replaceable emitters

- Reduces cost

High temperature mica

- Insulates nickel chromium resistance wire, permitting longer heater life

High emissivity coating on emitter strips

- Improves radiant heating efficiency

7/8 in. (22.2 mm) thick thermal insulation

- Backs the emitter strips to reduce backside losses

Uniform full surface heat source

- Provides better, more even heat

Special requirements are easily met

- Ensures availability of custom sizes and ratings

Next day shipment on RAPID SHIP heaters

- Provides quick delivery to meet customer's needs

Typical Applications

- Thermoforming
- Textile drying
- Paint curing
- Powder coating fusing
- Shrink wrapping
- Circuit board soldering

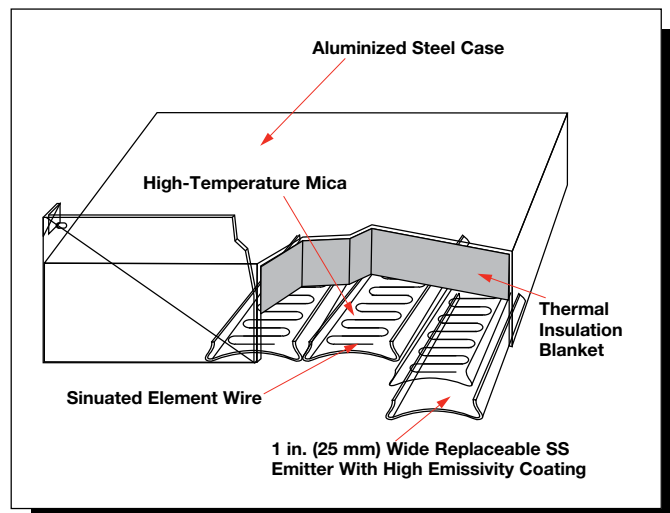

Radiant Heaters

RAYMAX Panel Heaters

RAYMAX 1120

Applications and Technical Data

Sizes and Ratings

Face Temperature: 1100°F (595°C) max.

Wattage: Watt densities up to 20 W/in² (3 W/cm²)

Voltage: Customer specified up to 480V. Balanced 3-phase available on unit widths divisible by three.

Note: Small heaters may not be able to be built at high voltages. Contact your Watlow representative to discuss specific application requirements.

Terminals: Non-standard locations are available. Please specify.

Tolerance: ±1/16 in. (1.6 mm)

Typical Peak Energy Wavelength: 3-3.5 microns

Note: New designs require a minimum charge per design.

Specifications

Heater Dimensions	Min.	Max.	Increments
Width: in. (mm)	1 (25)	24 (610)	1 (25.0)
Length: in. (mm)	6 (152)	72 (1829)	0.06 (1.5)
Area: in ² (cm ²)	6 (39)	864 (5574)	Any

Note: Less than maximum length x width may exceed the maximum area.

Options

- Terminal box
- Thermowell
- Thermocouple welded to hot face
- Thermocouple pocket
- Mounting studs

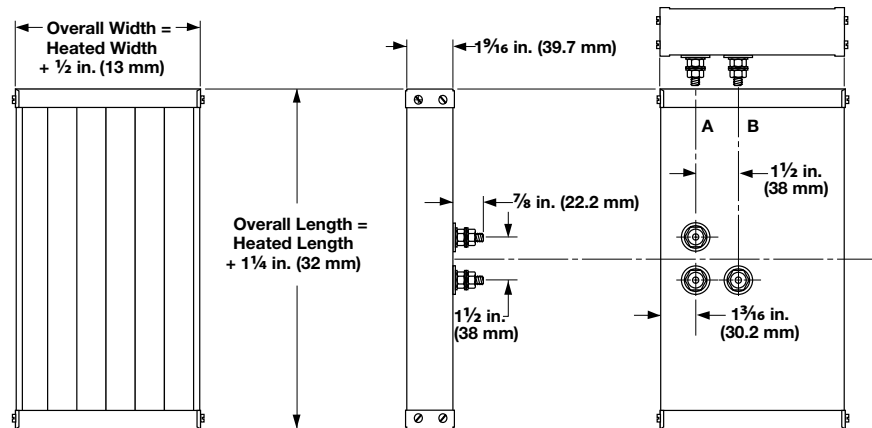

Panel Overall Size in. (mm)		Panel Heated Size in. (mm)		Volts	Watts	Watt Density W/in ² (W/cm ²)	Approx. Net Wt. lbs (kg)	Delivery	Part Number
Width	Length	Width	Length						
6 1/2 (165)	25 1/4 (641)	6 (152)	24 (610)	240	2880	20 (3.1)	6 (2.7)	RS	P0624AX050
12 1/2 (318)	13 1/4 (337)	12 (305)	12 (305)	240	2880	20 (3.1)	6 (2.7)	RS	P1212AX030
12 1/2 (318)	25 1/4 (641)	12 (305)	24 (610)	240	5760	20 (3.1)	12 (5.4)	RS	P1224AX062
12 1/2 (318)	49 1/4 (1251)	12 (305)	48 (1219)	480 3-phase	11,520	20 (3.1)	24 (10.8)	RS	P1248AX073

RAPID SHIP

- RS - Next day shipment

Notes:

- Panels are equipped with a terminal box, a thermocouple well with bayonet adapter and mounting studs.
- Radiant panels must be properly applied for safe operation.
- Please contact your Watlow representative with the application before ordering.

Radiant Heaters

RAYMAX Panel Heaters

RAYMAX 1220 and 2030

Easy to install and capable of high surface temperatures, the RAYMAX 1220 and 2030 panel heaters are ideal for many process heating applications requiring “hot-face” temperatures above 1000°F (540°C).

Each unit consists of a ceramic fiber heater mounted in a 2½ in. (64 mm) deep sheet metal case providing thermal insulation. The case includes post terminals for electrical connections and a mounting system that can be used with virtually any flat ceramic fiber unit. Since any flat unit heating element configuration can be used—exposed sinuated, embedded coil or foil elements—watt density and temperature capabilities can be tailored to meet a specific radiant application.

Performance Capabilities

- RAYMAX 2030 (uses sinuated or coil elements): temperatures up to 2000°F (1095°C); watt densities up to 30 W/in² (4.7 W/cm²)
- RAYMAX 1220 (uses an etched foil element): temperatures up to 1200°F (650°C); watt densities up to 20 W/in² (3 W/cm²)
- Maximum voltage up to 600V

Features and Benefits

Lightweight, low mass design

- Allows fast response to controllers

Self insulation with 2½ in. (64 mm) thick mounting case

- Provides high efficiency

Thermocouple mounting clamp

- Makes process system control easier

Aluminized steel case

- Handles temperatures up to 1100°F (595°C)

Special hot-face heating patterns

- Provides a design made specifically for an application using an etched foil RAYMAX 1220

Typical Applications

- Conveyor furnaces
- High-temperature vessel heating
- Tempering and annealing processes for glass, wire, ceramics and metals
- Coating, curing and drying of inks, paints, plastics and films

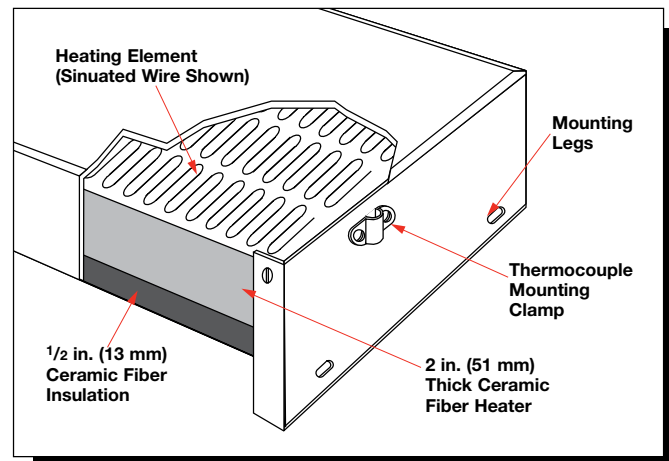
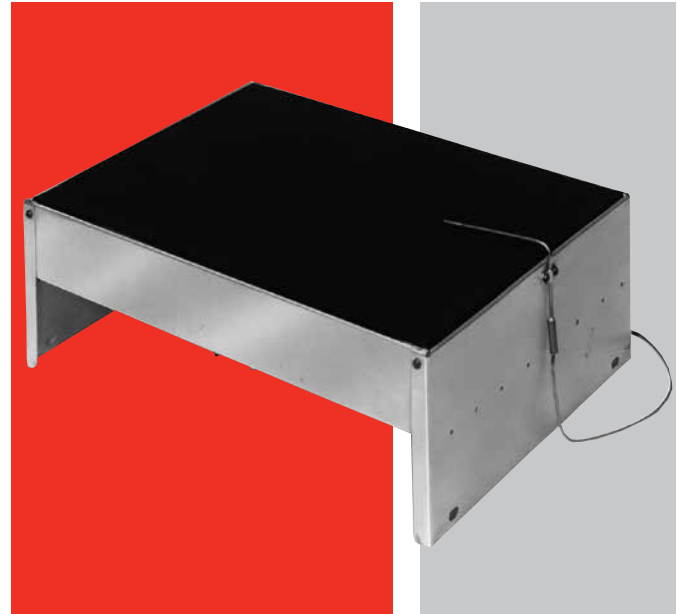

Radiant Heaters

RAYMAX Panel Heaters

RAYMAX 1220

Ceramic Fiber with Foil Element

Panel Overall Size ±1/16 in. (1.5 mm)		Panel Nominal Heated Size in. (mm)		Volts	Watts	Watt Density		Approx. Net Wt.		Delivery	Part Number
Width	Length	Width	Length			W/in ²	(W/cm ²)	lbs	(kg)		
4 1/4 (108)	12 (305)	4 (102)	12 (305)	120	950	19.8	(3.1)	2.8	(1.3)	M	VP504A12F
4 1/4 (108)	24 (610)	4 (102)	24 (610)	240	1900	19.8	(3.1)	4.8	(2.2)	M	VP504A24F
8 1/4 (210)	12 (305)	8 (203)	12 (305)	240	1900	19.8	(3.1)	4.5	(2.1)	M	VP508A12F ^①
8 1/4 (210)	24 (610)	8 (203)	24 (610)	240	3800	19.8	(3.1)	7.7	(3.5)	M	VP508A24F

• M - Manufacturing lead times

All units in this table are suitable for use up to 1200°F (650°C) maximum surface temperature.

^① Thermocouple clasp is not included in the length.

RAYMAX 2030

Ceramic Fiber with Sinuated Element

Nominal Heated Width in. (mm)	Nominal Heated Length in. (mm)	Volts	Watts	Watt Density W/in ² (W/cm ²)	Approx. Net Wt. lbs (kg)	Delivery	Part Number
4 (102)	6 (152)	30	500	20.8 (3.2)	1.9 (0.9)	M	VP504A06T
	12 (305)	120	925	19.3 (3.0)	3.1 (1.4)	M	VP504A12T ^①
	18 (457)	120	1400	19.4 (3.0)	4.1 (1.9)	M	VP504A18T ^①
	24 (610)	240	1850	19.5 (3.0)	5.2 (2.4)	M	VP504A24T ^①
	30 (762)	240	2250	19.6 (3.1)	6.3 (2.9)	M	VP504A30T ^①
	36 (914)	240	3200	22.2 (3.4)	7.4 (3.3)	M	VP504A36T ^①
6 (152)	6 (152)	60	650	18.1 (2.8)	2.4 (1.1)	M	VP506A06T ^①
	12 (305)	120	1250	17.4 (2.7)	4.1 (1.9)	M	VP506A12T
	18 (457)	240	2000	18.5 (2.9)	5.8 (2.6)	M	VP506A18T
	24 (610)	120	2500	17.4 (2.7)	7.4 (3.3)	M	VP506A24T
	24 (610)	240	2500	17.4 (2.7)	7.4 (3.3)	M	VP506A24U
	30 (762)	240	3400	18.9 (2.9)	9.0 (4.1)	M	VP506A30T
8 (203)	36 (914)	240	4000	18.5 (2.9)	10.6 (4.8)	M	VP506A36T
	12 (305)	120	1800	18.8 (2.9)	4.7 (2.4)	M	VP508A12T
	18 (457)	240	3000	20.8 (3.2)	7.4 (3.3)	M	VP508A18U ^①
	24 (610)	240	3600	18.8 (2.9)	9.5 (4.3)	M	VP508A24T
	30 (762)	240	5000	20.8 (3.2)	11.7 (5.3)	M	VP508A30T
	36 (914)	240	6000	20.8 (3.2)	13.9 (6.3)	M	VP508A36T
10 (254)	12 (305)	120	2000	16.7 (2.6)	6.3 (2.9)	M	VP510A12T
	18 (457)	120	3600	20.0 (3.1)	9.0 (4.1)	M	VP510A18T
	24 (610)	240	4500	17.9 (2.8)	11.7 (5.3)	M	VP510A24T
	30 (762)	240	6000	20.0 (3.1)	14.4 (6.5)	M	VP510A30T
	36 (914)	240	7200	19.4 (3.0)	17.1 (7.8)	M	VP510A36T

CONTINUED

• M - Manufacturing lead times

All units in this table are suitable for use up to 1800°F (982°C) maximum surface temperature.

^①Vee sinuated

Radiant Heaters

RAYMAX Panel Heaters

RAYMAX 2030 (Continued)

Ceramic Fiber with Sinuated Element

Nominal Heated Width		Nominal Heated Length		Volts	Watts	Watt Density		Approx. Net Wt.		Delivery	Part Number
in.	(mm)	in.	(mm)			W/in ²	(W/cm ²)	lbs	(kg)		
12	(305)	12	(305)	120	2500	17.4	(2.7)	7.4	(3.3)	M	VP512A12T
		12	(305)	240	2500	17.4	(2.7)	7.4	(3.3)	M	VP512A12U ^①
		18	(457)	240	4000	18.5	(2.9)	10.6	(4.8)	M	VP512A18T
		24	(610)	240	6000	20.8	(3.2)	13.9	(6.3)	M	VP512A24T
		30	(762)	240	7200	20.0	(3.1)	17.1	(7.8)	M	VP512A30T
		36	(914)	240	8400	19.4	(3.0)	20.3	(9.2)	M	VP512A36T ^①
14	(356)	12	(305)	240	3500	20.8	(3.2)	8.5	(3.8)	M	VP514A12T
		18	(457)	240	4900	19.4	(3.0)	12.2	(5.5)	M	VP514A18T
		24	(610)	240	7000	20.8	(3.2)	16.0	(7.3)	M	VP514A24T
		30	(762)	240	8400	20.0	(3.1)	19.8	(9.0)	M	VP514A30T ^①
		36	(914)	240/240	9800	19.4	(3.0)	23.6	(10.7)	M	VP514A36T
16	(406)	12	(305)	240	3600	18.8	(2.9)	9.5	(4.3)	M	VP516A12T
		18	(457)	240	5700	19.8	(3.1)	13.9	(6.3)	M	VP516A18T
		24	(610)	240	7100	18.5	(2.9)	18.2	(8.2)	M	VP516A24T
		30	(762)	240/240	9600	20.0	(3.1)	22.5	(10.2)	M	VP516A30T
		36	(914)	240/240	11500	20.0	(3.1)	26.8	(12.2)	M	VP516A36T

• M - Manufacturing lead times

All units in this table are suitable for use up to 1800°F (982°C) maximum surface temperature.

^①Vee sinuated

Part Number

①	②	③	④	⑤	⑥	⑦	⑧	⑨	⑩	⑪	⑫	⑬	⑭
V	P	5	0	8	A	1	2	T	Modification Options	0	0	0	0

① ② ③ ④ ⑤ ⑥ ⑦ ⑧ ⑨ Base Part Number													
VP508A12T													
⑩ Modification Options													
1 =	3 in. (76 mm) leg height and terminal box												
4 =	1/4 / 20 mounting studs												
5 =	1/4 / 20 mounting studs and terminal box												
M =	1 in. (25 mm) leg height												
R =	1 in. (25 mm) leg height and terminal box												
W =	Terminal box in standard location												
Y =	3 in. (76 mm) leg height												

Radiant Heaters

RAYMAX Panel Heaters

RAYMAX 1330

The RAYMAX 1330 is the only radiant heater featuring specially insulated heater emitter strips for higher performance. Watlow's unique compacted mineral insulation electrically insulates the element wire, creating superior heat transfer and higher operating capabilities.

The RAYMAX 1330 lasts longer due to its rugged stainless steel construction. It features a high emissivity black coating and a uniform, full-surface heat source for better efficiency.

Performance Capabilities

- Maximum face temperature: 1300°F (700°C)
- Maximum watt density: 30 W/in² (4.7 W/cm²)
- Typical peak energy wavelength: 3-3.6 microns
- Maximum voltage up to 480V

Features and Benefits

Field replaceable emitter strips

- Eliminates the cost to buy a whole new radiant heater

Rugged metal construction

- Protects the heater from contaminants

No reflectors

- Eliminates cleaning and replacement

No fragile glass or ceramic elements

- Prevents possible safety hazards

Backside insulation

- Results in better heating efficiency

Responsive face temperature sensing options

- Increases accuracy

Typical Applications

- Thermoforming plastics and composites
- Circuit board soldering
- Heat shrinking of plastic

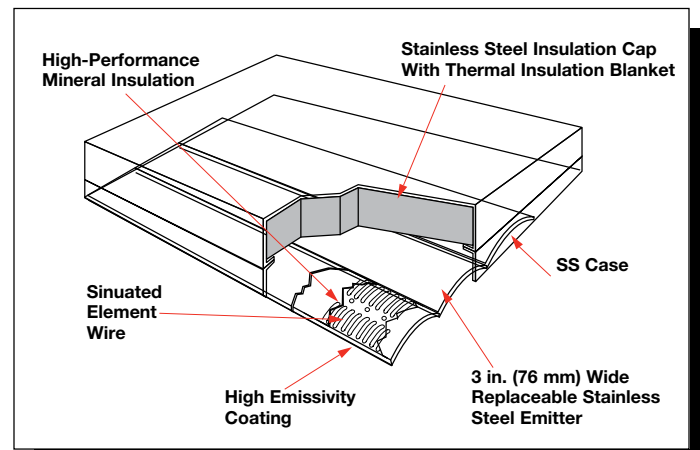

Radiant Heaters

RAYMAX Panel Heaters

RAYMAX 1330

Applications and Technical Data

Sizes and Ratings

Thickness: 2.46 in. (62.5 mm)

Voltage: Customer specified up to 480V. Balanced 3-phase is available on units with three or six emitters.

Note: Small heaters may not be able to be built at high voltages. Contact your Watlow representative to discuss specific application requirements.

Maximum Watt Density: 30 W/in² (4.7 W/cm²)

Maximum Face Temperature: 1300°F (700°C)

Typical Peak Energy Wavelength: 3 microns

Standard Tolerances: ±1/16 in. (1.6 mm)

Specifications

Heater Dimensions	Min.	Max.	Increments
Length: in. (mm)	12 (305)	30.5 (775)	0.06 (1.5)

Number of Emitters	Heated Width in. (mm)	Overall Width in. (mm)
1	2.95 (75)	3.36 (85)
2	6.14 (156)	6.54 (166)
3	9.33 (237)	9.73 (247)
4	12.51 (318)	12.92 (328)
5	15.70 (399)	16.11 (409)
6	18.89 (480)	19.29 (490)

Options

- Terminal box
- Thermowell
- Thermocouple welded to hot face
- Thermocouple pocket
- Mounting studs

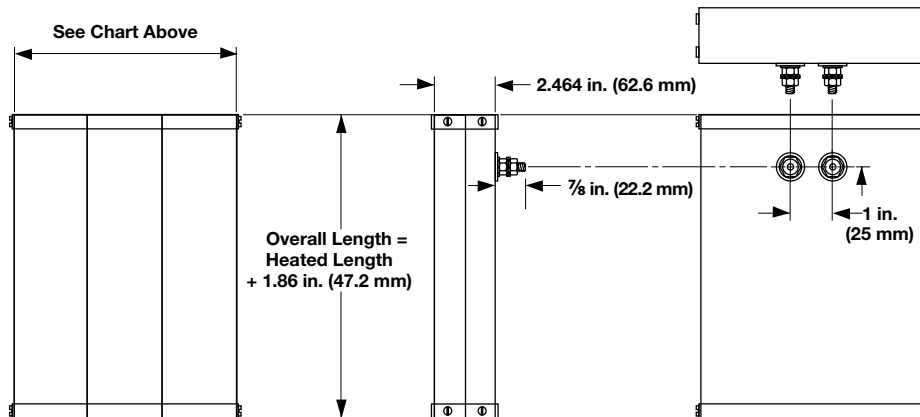

Radiant Heaters

RAYMAX Panel Heaters

Mounting Accessories

Mounting Studs

Standard $1/4$ -20 x $1\frac{1}{2}$ in. (38 mm) or (M6-1 x 40) steel studs are welded to the case. For best support, studs should be approximately located on 12 in. (305 mm) centers. Contact your Watlow representative for exact locations on specific heaters.

Available with RAYMAX 1010, 1120, 1220, 1330 and 2030.

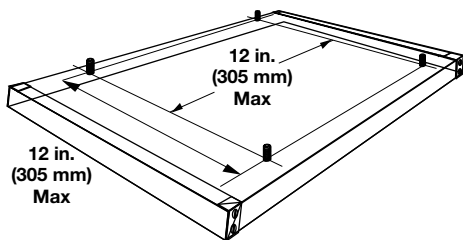

Mounting Legs

Mounting legs are extensions of the steel end caps with mounting slots for bolting directly to field support members. There is no extra charge for legs. They can be supplied in half inch increments from 0.5 in. (13 mm) to 3 in. (76 mm). Slots are not provided in legs less than 1 in. (25 mm) long.

For panels over 24 in. (610 mm) long, mounting studs are recommended for the best panel support.

Available with RAYMAX 1120, 1220 and 2030 (Available as an extended capability for RAYMAX 1010 and 1330.)

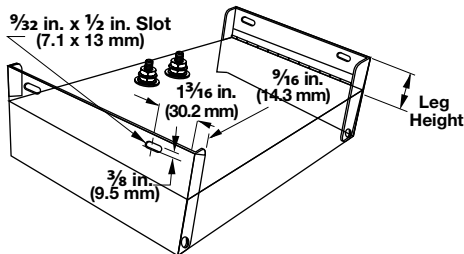

Application note: Allow for some thermal expansion of the heater case during operation. An expansion of up to one percent can occur when the case reaches its normal maximum limit of 1100°F (595°C). If the equipment has mounting screws to connect to the slots in the mounting legs, allow for a small amount of extra length. If mounting holes are used to interface with the mounting studs on the back of the RAYMAX case, make sure that the holes are oversized. Use washers and avoid overtightening the screws.

Terminal Accessories

Terminal Box

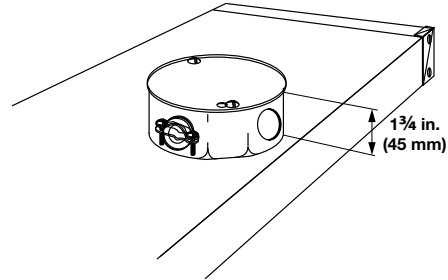

To protect electrical connections, a standard NEMA octagon terminal box is available. The standard size is $3\frac{9}{16}$ x $3\frac{9}{16}$ x $1\frac{1}{2}$ in. (90.5 x 90.5 x 38 mm) with knockouts for $1/2$ in. (13 mm) conduit. Other NEMA sizes are available as an extended capability.

Care should be taken to use lead wire capable of withstanding the ambient temperatures.

Available with RAYMAX 1010, 1120, 1220, 1330 and 2030.

Zoning

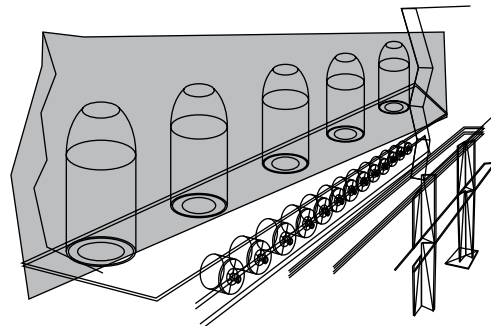

Watt densities can be varied across the entire width of RAYMAX heaters. If desired, each zone can have an individually controlled power supply.

Zoning can be very valuable when part of the product requires more heat, or when it must compensate for heat losses at the edges. Separately turning off part of the heated width enables the heater to adjust for various widths of material.

Available with RAYMAX 1010, 1120 and 1330.

(Available as an extended capability for RAYMAX 1220 and 2030.)

Radiant Heaters

RAYMAX Panel Heaters

Temperature Control

Thermowells

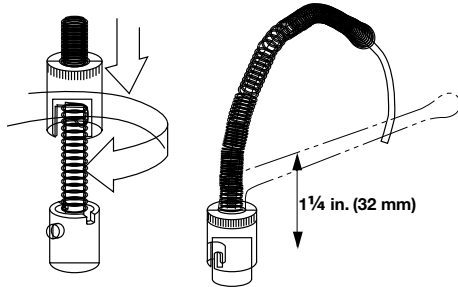

A thermowell allows a thermocouple to be used with a bayonet fitting to monitor heater temperature. The thermowell is located on the back of the panel to allow easy access for thermocouple replacement. A spring tension holds the tip of the thermocouple in contact for close control of the heater temperature. A thermocouple is not included.

Available with RAYMAX 1010, 1120 and 1330.

Welded Thermocouple

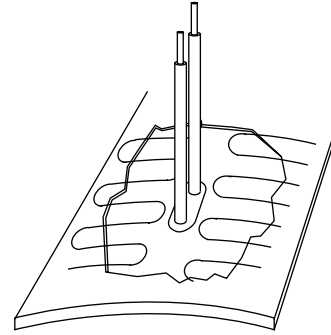

A thermocouple junction is welded to the emitting surface to provide optimum temperature sensing accuracy and responsiveness. This option permits the actual radiating face temperature to be precisely monitored and controlled. The standard length of the thermocouple wire is 12 in. (305 mm).

Available with RAYMAX 1330.

Thermocouple Clamps

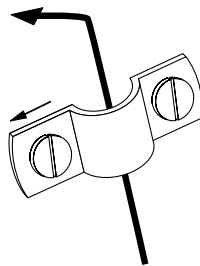

A thermocouple mounting clamp can be provided on the end of the heater case. The clamp is suitable for $\frac{1}{8}$ in. (3.2 mm) and $\frac{1}{4}$ in. (6 mm) outside diameter sheath thermocouples bent to 90° so that the sensing tip is just above and lightly touching the hot face at an element location.

Available with RAYMAX 1220 and 2030.

Thermocouple Pocket

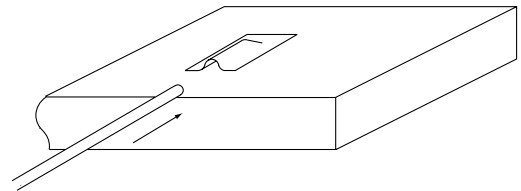

A thermocouple pocket welded to the emitting surface accepts a 0.063 in. (1.6 mm) diameter thermocouple (not included). This option provides accurate temperature sensing and easy thermocouple replacement.

Available with RAYMAX 1010, 1120 and 1330.

Radiant Heaters

**EXTENDED
CAPABILITY**

Extended Capability For RAYMAX Panel Heaters

Specifications

RAYMAX 1120

Heater Dimensions	Min.	Max.	Increments
Width: in. (mm)	24 (610)	36 (914)	1 (25.0)
Length: in. (mm)	6 (152)	94 (2388)	0.06 (1.5)
Area: in ² (cm ²)	6 (38.7)	864 (5574.2)	Any

Note: Less than maximum length x width may exceed the maximum area.

RAYMAX 1330

Number of Emitters	Heated Width in. (mm)	Overall Width in. (mm)
7	22.08 (560.8)	22.48 (570.9)
8	25.26 (641.6)	25.67 (652.0)

Mounting Legs

Mounting legs are extensions of the steel end caps with mounting slots for bolting directly to field support members. They can be supplied in half inch increments from 0.5 in. (13 mm) to 3 in. (76 mm). Slots are not provided in legs less than 1 in. (25 mm) long.

For panels over 24 in. (610 mm) long, mounting studs are recommended for the best panel support.

Available as an extended capability for RAYMAX 1010 and 1330.

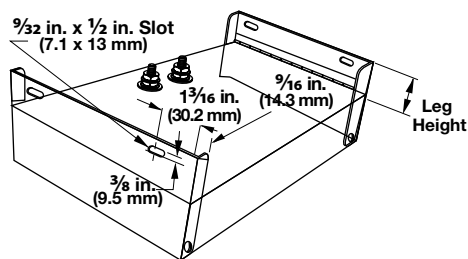

Application note: Allow for some thermal expansion of the heater case during operation. An expansion of up to one percent can occur when the case reaches its normal maximum limit of 1100°F (595°C). If the equipment has mounting screws to connect to the slots in the mounting legs, allow for a small amount of extra length. If mounting holes are used to interface with the mounting studs on the back of the RAYMAX case, make sure that the holes are oversized. Use washers and avoid overtightening the screws.

Zoning

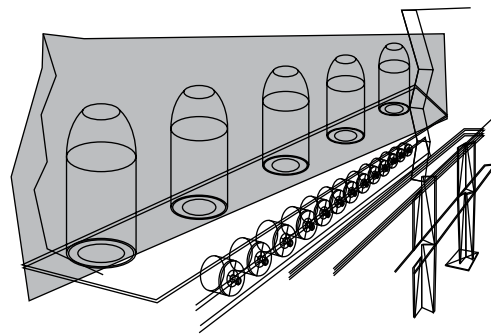

Watt densities can be varied across the entire width of RAYMAX heaters. If desired, each zone can have an individually controlled power supply.

Zoning can be very valuable when part of the product requires more heat, or when it must compensate for heat losses at the edges. Separately turning off part of the heated width enables the heater to adjust for various widths of material.

Available as an extended capability for RAYMAX 1220 and 2030.

Wiring Raceway

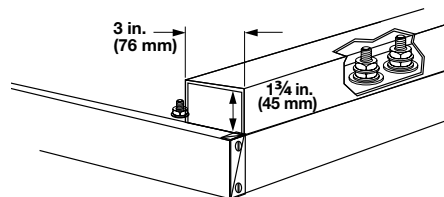

A steel raceway provides electrical and physical protection for all terminal connections. This can be particularly useful for multi-zone panels.

Available as an extended capability for RAYMAX 1010, 1120, 1220, 1330 and 2030.

Radiant Heaters

EXTENDED
CAPABILITY

Extended Capabilities For Mineral Insulated (MI) Band and Strip Emitters

These heaters are constructed using Watlow's exclusive mineral insulation, which features high thermal conductivity. The band and strip emitters are constructed of rugged stainless steel sheath and a high emissivity coating.

Performance Capabilities

- Maximum operating temperature up to 1300°F (704°C)
- Maximum watt densities up to 30 W/in² (4.7 W/cm²)

Sizes

Strip Emitters

Width: 2 in. (51 mm), 3 in. (76 mm)
Length: 6 in. (152 mm) minimum,
31 in. (787 mm) maximum

Band Emitters

Width: 1 in. (25 mm), 2 in. (51 mm),
3 in. (76 mm) maximum

- Segment length: 6 in. (152 mm) minimum to 42 in. (1067 mm) maximum
- Contact your Watlow representative for partial arcs up to full 360° coverage
- High emissivity coating on inside is standard. For high emissivity coating on the outside, contact your Watlow representative.
- Post terminals are standard. High-temperature leads are available on bands only.

Options

- Mounting studs
- Mounting clips for 3 in. (76 mm) wide emitter strips, part #MM6063
- Thermocouple welded to sheath
- Thermocouple pocket welded to sheath

Features and Benefits

Exclusive mineral insulation

- Combines dielectric strength and superior thermal conductivity
- Transfers heat rapidly to the sheath

High thermal conductivity of MI

- Provides an almost instant response to temperature control
- Eliminates thermal lag and temperature overshoot associated with other heaters

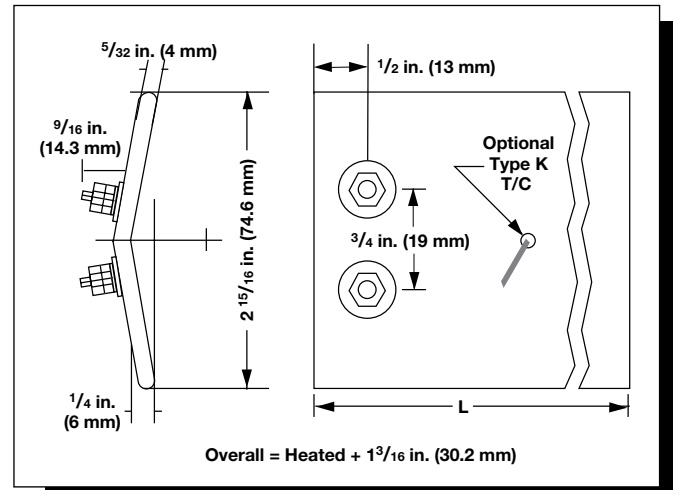

Mounting Clip (Part # MM6063)
(For 3 in. (76 mm) wide strip heater)

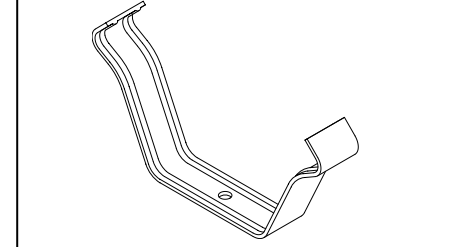

Typical Applications

- Heating rotating drums and rollers
- Tube ovens
- Small spot heating
- Heat shrinking and curing wire coatings
- Heat laminating wheels

