

# Strip/Clamp-On Heaters

| Strip/Clamp-On Heaters        | Sheath Materials    | Max. Operating Temperatures |     | Typical Max. Watt Densities |                   | Page       |
|-------------------------------|---------------------|-----------------------------|-----|-----------------------------|-------------------|------------|
|                               |                     | °F                          | °C  | W/in <sup>2</sup>           | W/cm <sup>2</sup> |            |
| <b>Mineral Insulated (MI)</b> | 304 stainless steel | 1400                        | 760 | 140                         | 21.7              | <b>477</b> |
| <b>375 High-Temperature</b>   | Aluminized steel    | 1100                        | 595 | 100                         | 15.5              | <b>481</b> |
| <b>FIREBAR® Clamp-On</b>      | Alloy 800           | 1400                        | 760 | 120                         | 18.6              | <b>489</b> |
|                               | 304 stainless steel | 1200                        | 650 | 120                         | 18.6              |            |
| <b>Thick Film Conduction</b>  | 430 stainless steel | 1025                        | 550 | 75                          | 11.6              | <b>490</b> |



Strip/Clamp-On Heaters



# Strip/Clamp-On Heaters

## Mineral Insulated (MI) Strip Heaters

The MI strip heater is a thin, responsive heater that uses the most advanced heater construction techniques. A nickel-chromium element wire is embedded in Watlow's exclusive mineral insulation material, which has a much higher thermal conductivity than the mica and hard ceramic insulators used in conventional heaters. This thin layer of insulation brings the element wire closer to the heater sheath. The result is heat flows easily from the element wire to the sheath allowing the wire to run cooler than conventional heaters and increasing heater life.

### Performance Capabilities

- Sheath temperatures up to 1400°F (760°C)
- Watt densities up to 140 W/in<sup>2</sup> (21.7 W/cm<sup>2</sup>)
- Maximum voltage up to 480VAC
- UL® component recognition for most 240VAC or less designs (UL® File #E52951)

### Features and Benefits

#### Higher watt densities than any other strip heater

- Provides faster heat up

#### Exclusive mineral insulation

- Combines dielectric strength and superior thermal conductivity
- Transfers heat rapidly to the sheath

#### 304 stainless steel sheath

- Maintains the high compaction of mineral insulation
- Produces a rigid heater

### Typical Applications

- Solder pots
- Zinc die-casting equipment
- Die and mold heating
- High-temperature resins
- Tank and platen heating
- Ovens
- Packaging equipment

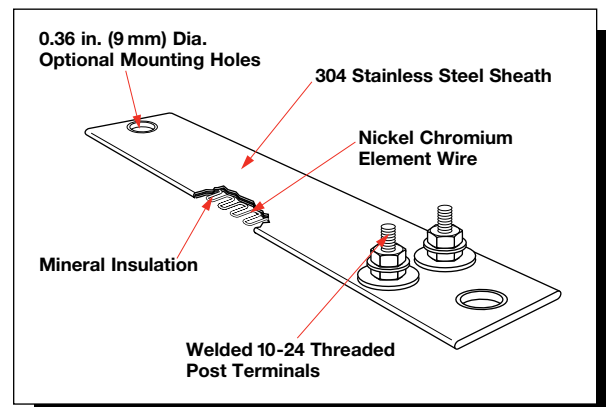
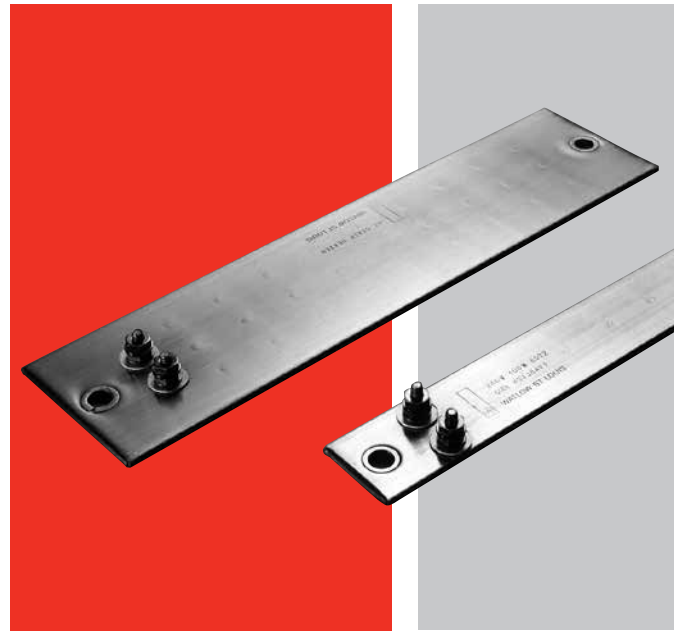

**RAPID SHIP**

- Next day shipment

# Strip/Clamp-On Heaters

## Mineral Insulated (MI) Strip Heaters

### Applications and Technical Data

#### Calculating Watt Density

Watt density is the amount of wattage per square inch of heated area. To determine watt density, divide the total wattage by the heated area.

$$\text{Watt Density} = \frac{\text{Wattage}}{\text{Heated Area}}$$

To apply this equation, the heated area is the total contact surface of the heater less areas of no-heat found around terminals, mounting holes, etc.

**Heated Area = Total Contact Area - No-Heat Area**

**To calculate the heated area:**

- Using the chart below, locate the **no-heat factor** corresponding to the type of heater being considered.
- To use the formula below, insert the no-heat factors, length and width (in inches).

$$\text{Heated Area} = (\text{Overall Length} - \text{No-Heat Factor}) \times \text{Width}$$

| Type  | No-Heat Factor (in.) |
|---|----------------------|
| <b>1 in. Wide</b>                                   |                      |
| 1 in. wide post terminal 1 on 1                     | 1.75                 |
| 1 in. wide post terminal 1 on 1 with mounting holes | 3.00                 |
| <b>For all other widths</b>                         |                      |
| 2 on 1 post terminal                                | 1.18                 |
| 2 on 1 with mounting holes                          | 3.18                 |

The drawings on the next page and the graph on this page will help in selecting the correct watt density for a particular application. First, refer to the drawings to determine the heated area of the heater. Then, use the

watt density formula and graph to ensure that the maximum watt density of the heater does not exceed the specific application requirements.

$$\text{Watt Density} = \frac{\text{Wattage}}{\text{Heated Area}}$$

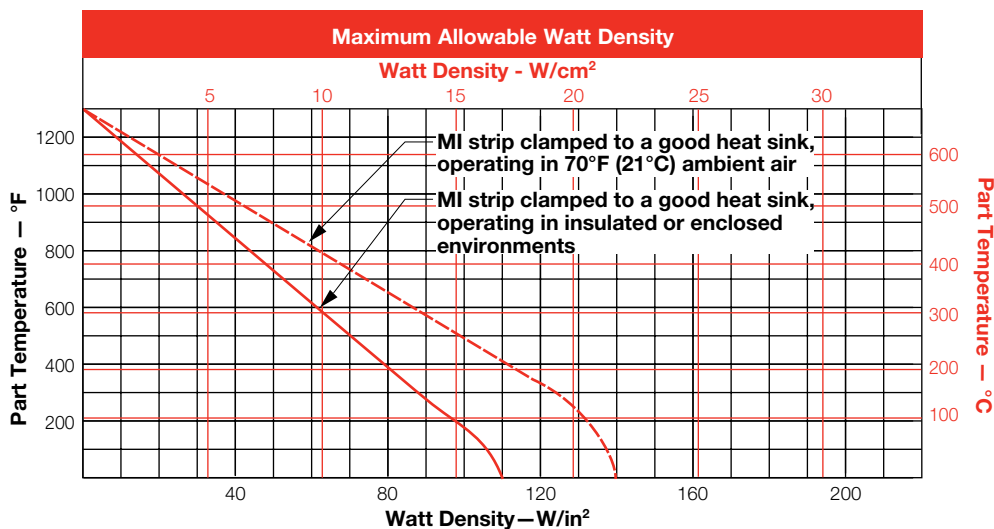

# Strip/Clamp-On Heaters

## Mineral Insulated (MI) Strip Heaters

### Applications and Technical Data (Continued)

#### Specifications

##### Width

- 1, 1½ and 2 in. (25, 38, 51 mm), tolerance  $\pm 1/32$

##### Length

- 8 to 30 in. (203 to 762 mm), tolerance  $\pm 1/8$

##### Terminations

- 1 in. (25 mm) wide—post terminals one-on-one
- 1½ to 2 in. (38 to 51 mm)—post terminals two-on-one

#### All Widths

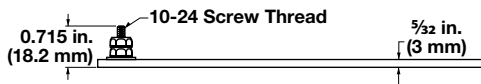

**Note:** In most applications, mounting holes alone do not provide adequate clamping. A clamp bar should be used for each 4 in. (102 mm) of heater length.

#### 1 in. (25 mm) Wide

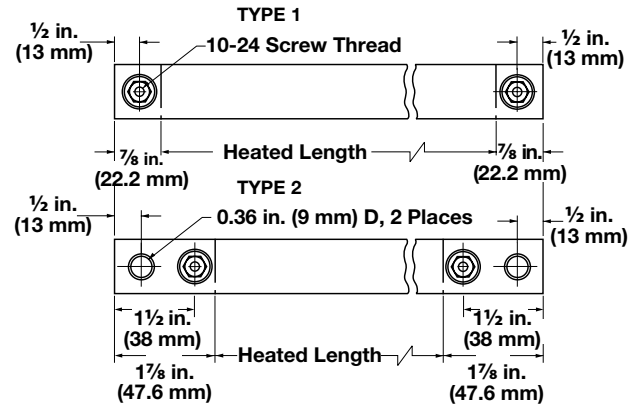

#### 1½ in. – 2 in. (38 – 51 mm) Wide

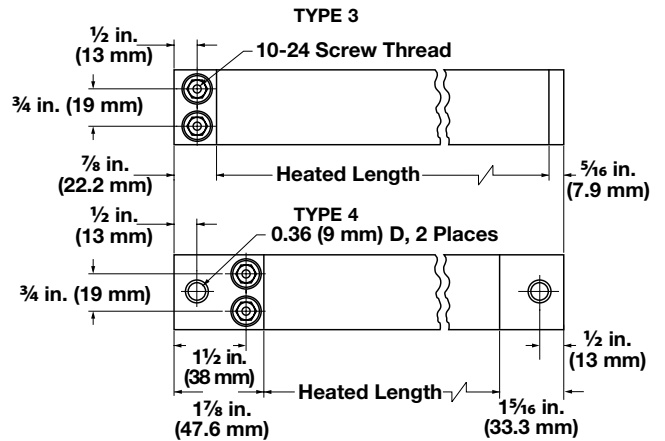

# Strip/Clamp-On Heaters

## Mineral Insulated (MI) Strip Heaters

### Applications and Technical Data (Continued)

#### Options

##### Thermocouple Pocket

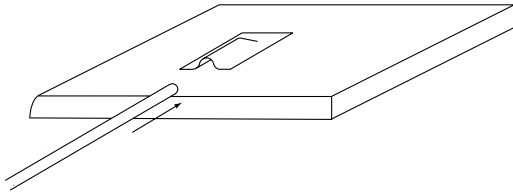

A thermocouple pocket welded to the back surface accepts a 0.063 in. (1.6 mm) diameter thermocouple. This option provides accurate temperature sensing and easy thermocouple replacement. Thermocouple not included.

#### Accessories

##### Ceramic Terminal Covers

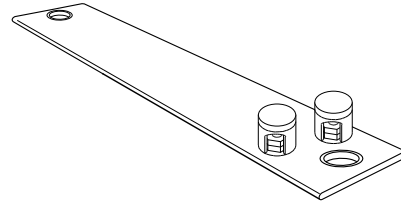

Ceramic terminal covers offer a convenient and economic method to insulate post terminals. They are sized for standard length posts with 10-24 screw thread size, supplied as an accessory item and shipped separately. Specify Z4918 and quantity.

#### Parallel Terminals Part Numbers—Type 3 and 4

| Width<br>in. (mm) | Length<br>in. (mm) | Volts | Power<br>(Watts) | Watt Density<br>W/in <sup>2</sup> (W/cm <sup>2</sup> ) | Approx.<br>Net Wt.<br>lbs. (kg) | Type | Part<br>Number               |
|-------------------|--------------------|-------|------------------|--|---------------------------------|------|------------------------------|
| 1 1/2 (38)        | 8 (203)            | 240   | 500              | 50 (7.8)   | 0.3 (0.15)                      | 3    | <b>MS1J8AS3</b>              |
| 1 1/2 (38)        | 12 (305)           | 120   | 350              | 26 (4.0)   | 0.5 (0.2)                       | 4    | <b>MS1J12AV2<sup>①</sup></b> |
| 1 1/2 (38)        | 12 (305)           | 240   | 350              | 26 (4.0)   | 0.5 (0.2)                       | 4    | <b>MS1J12AV3<sup>①</sup></b> |
| 1 1/2 (38)        | 12 (305)           | 240   | 800              | 49 (7.6)   | 0.5 (0.2)                       | 3    | <b>MS1J12AS2</b>             |
| 1 1/2 (38)        | 18 (457)           | 120   | 1000             | 40 (6.2)   | 0.8 (0.3)                       | 3    | <b>MS1J18AS1</b>             |
| 1 1/2 (38)        | 18 (457)           | 240   | 1000             | 40 (6.2)   | 0.8 (0.3)                       | 3    | <b>MS1J18AS2</b>             |

<sup>①</sup> Denotes units with mounting holes. Mounting holes are 0.36 in. (9 mm) in diameter and are intended for use with 1/4 in. (6 mm) bolts.

Centers of mounting holes are located 1/2 in. (13 mm) from the ends of the heater.

**RAPID SHIP**

- Next day shipment up to 5 pieces

# Strip/Clamp-On Heaters

## 375 High-Temperature Strip Heaters

Named for its 0.375 in. (9.5 mm) thickness, the rugged Watlow® 375 strip heater is capable of both high temperatures and high watt densities.

Watlow begins construction by accurately placing a coiled, nickel-chromium element wire in the center of the heater. The element wire is then embedded in magnesium oxide (MgO)-based insulation compacted into a solid mass creating excellent heat conductivity and high dielectric strength. The heater is then enclosed in aluminized steel or 430 stainless steel sheathing.

### Performance Capabilities

- Aluminized steel sheath temperatures up to 1100°F (595°C)
- 430 stainless steel sheath temperatures up to 1200°F (650°C)
- Watt densities up to 100 W/in<sup>2</sup> (15.5 W/cm<sup>2</sup>)
- UL® approved up to 240VAC (File No. E52951)
- CSA approved up to 600VAC (File No. LR7392)

### Features and Benefits

#### Nickel-chromium element wire is centered in the heater

- Assures uniform heat

#### Aluminized steel sheath

- Operates at higher temperatures and resists corrosion better than iron-sheathed heaters
- Minimizes heat-up time

#### Optional 430 stainless steel sheath

- Meets temperature requirements that reach up to 1200°F (650°C)

#### Post terminals, welded to the element wire

- Produces strong, trouble-free connections

#### Rigid 3/8 in. (9.5 mm) thick design

- Enables the heater to fit into many existing applications

#### Over 100 in-stock models in popular sizes and ratings

- Allows next day shipment

#### Available dimensions are 1 1/2 in. (38 mm) wide and 5 1/2 to 48 in. (140 to 1219 mm) long

- Fits a variety of application needs

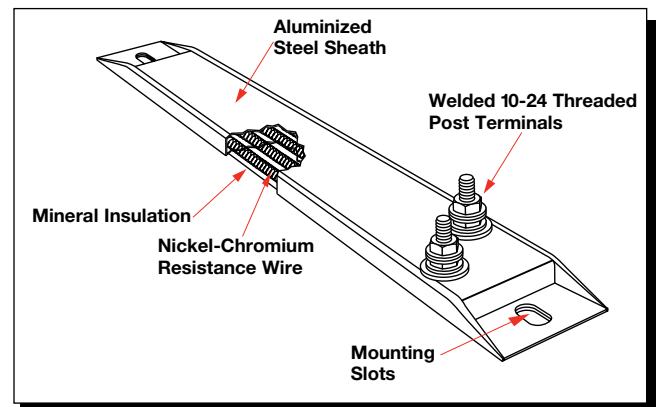
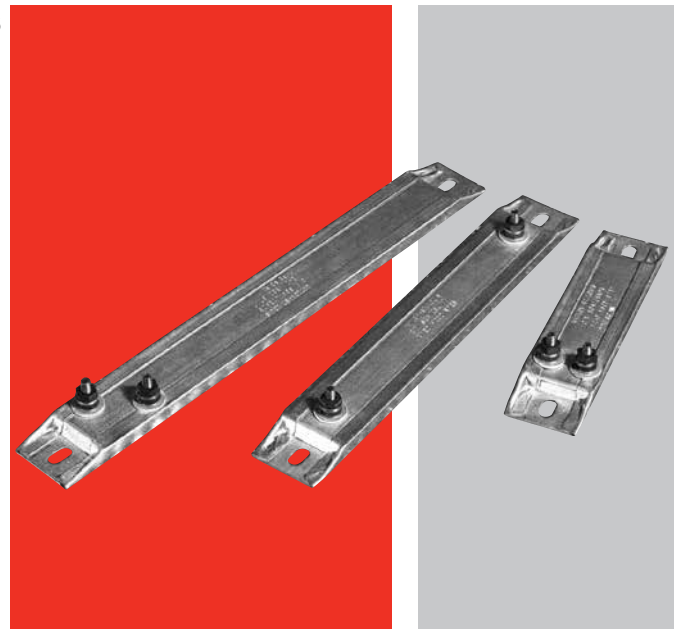

### Typical Applications

- Food warming
- Freeze and moisture protection
- Tank and platen heating
- Packaging
- Dies and mold heating
- Autoclaves
- Ovens
- Telecom

**RAPID SHIP**

- Next day shipment

# Strip/Clamp-On Heaters

## 375 High-Temperature Strip Heaters

### Applications and Technical Data

#### Calculating Watt Density

Use the *Maximum Allowable Watt Density* graphs and formulas to ensure the allowable watt density for the heater does not exceed the specific application requirements. **Watt density is calculated for one side of the heater only.**

#### Formulas

$$\text{Watt Density} = \frac{\text{Wattage}}{\text{Heated Area}}$$

Heated Area

$$\begin{aligned} \text{(Offset Terminals)} &= [\text{Overall Length (A)} \times 1.5 \text{ in.}] - 6 \text{ in}^2 \\ &= [\text{Overall Length (A)} \times 38 \text{ mm}] - 38.7 \text{ cm}^2 \end{aligned}$$

Heated Area

$$\begin{aligned} \text{(Parallel Terminals)} &= [\text{Overall Length (A)} \times 1.5 \text{ in.}] - 4.7 \text{ in}^2 \\ &= [\text{Overall Length (A)} \times 38 \text{ mm}] - 30.3 \text{ cm}^2 \end{aligned}$$

Heated Area

$$\begin{aligned} \text{(One-on-One Terminals)} &= [\text{Overall Length (A)} \times 1.5 \text{ in.}] - 6 \text{ in}^2 \\ &= [\text{Overall Length (A)} \times 38 \text{ mm}] - 38.7 \text{ cm}^2 \end{aligned}$$

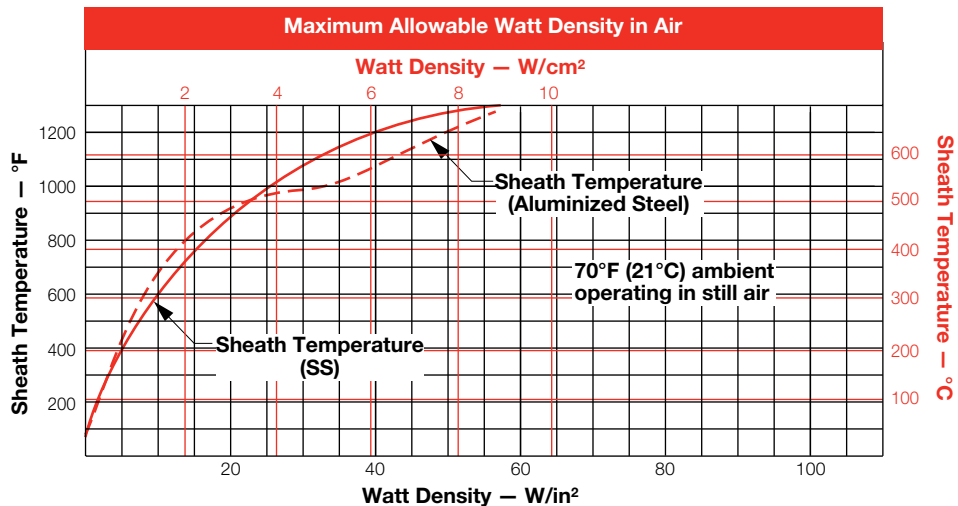
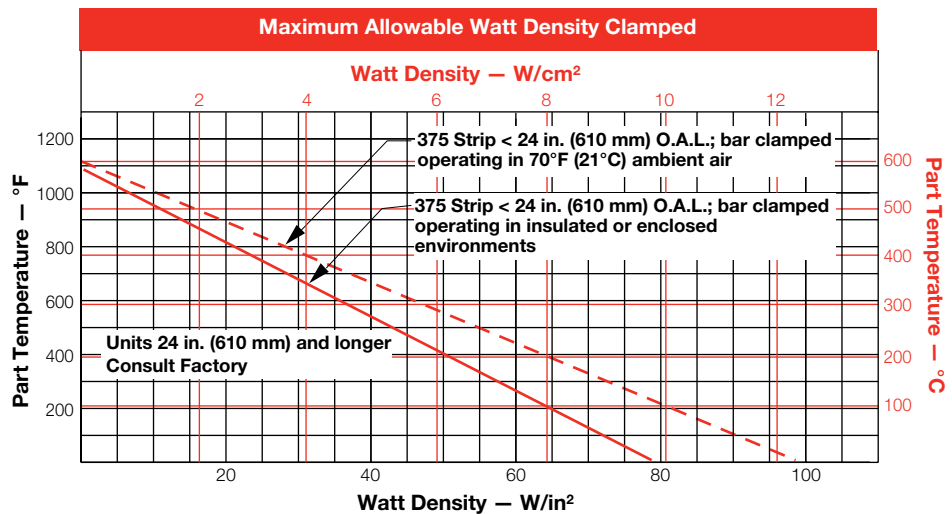



# Strip/Clamp-On Heaters

## 375 High-Temperature Strip Heaters

### Termination Options

#### Offset Terminals

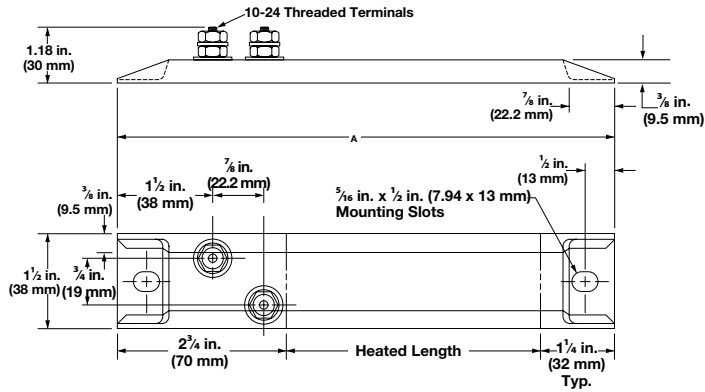

Two 10-24 threaded post terminals are offset from each other on the same end.

#### One-on-One Terminals

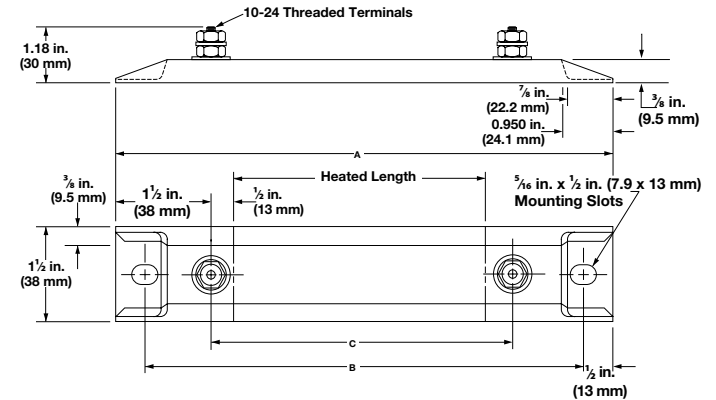

Two 10-24 threaded post terminals are placed one on each end.

#### Parallel Terminals

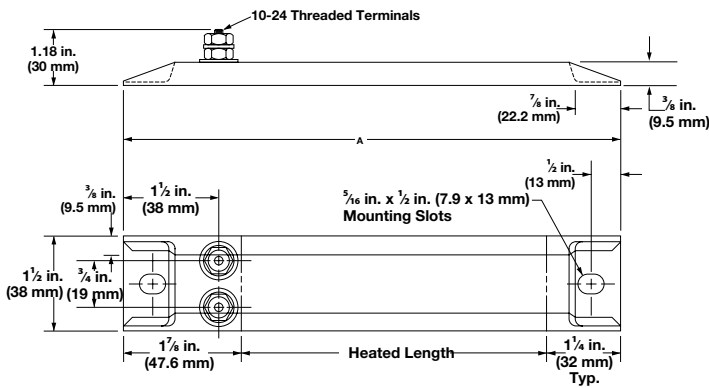

Two 10-24 threaded post terminals are used; both terminals on one end.

#### In-Line Terminals

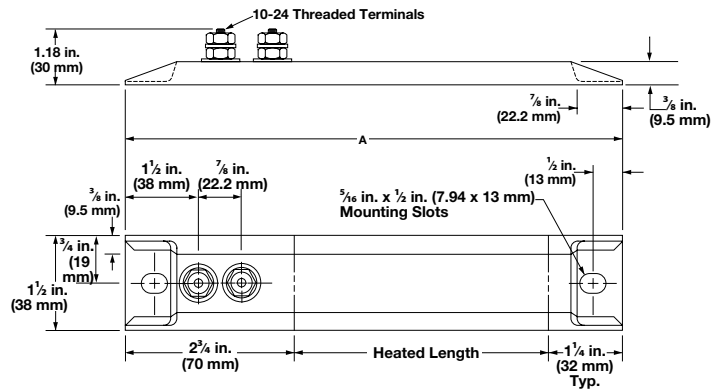

Two 10-24 threaded post terminals are in-line with each other on the same end.

# Strip/Clamp-On Heaters

## 375 High-Temperature Strip Heaters

### Termination Options (Continued)

#### Metallic Terminal Boxes - Variations

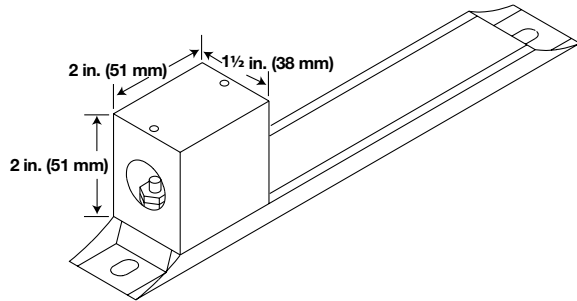

Available on in-line terminals only.

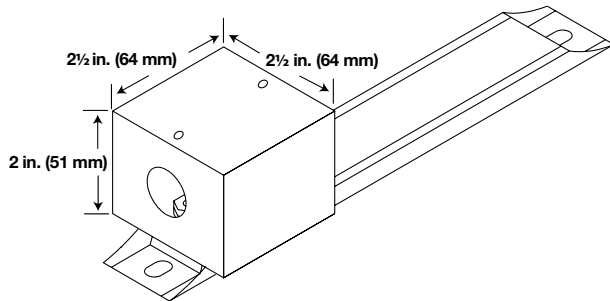

Available on offset terminals from stock and manufactured.

Metallic terminal boxes are available from stock on offset terminals. Terminal boxes act as a safety feature by covering the terminals. A conduit may be attached to the box through  $\frac{7}{8}$  in. (22.2 mm) diameter holes in the ends of the box. To order, specify **terminal box**.

### Accessories

#### Ceramic Terminal Covers

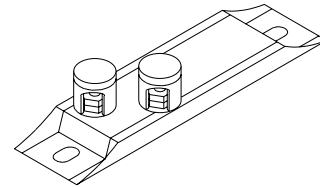

Ceramic terminal covers offer a convenient and economic method to insulate post terminals. They are sized for standard length posts with 10-24 screw thread size, supplied as an accessory item and shipped separately. Specify **Z4918** and quantity.

#### Secondary Insulation Bushings

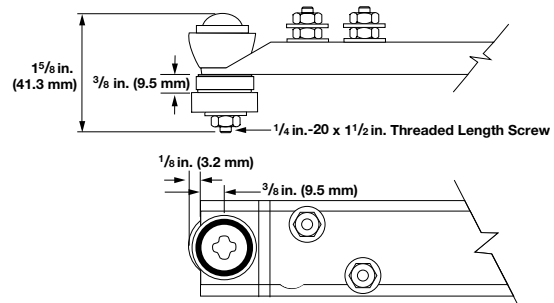

Insulators are suitable when air heating and/or voltage to ground is a concern. A secondary insulation bushing kit, part number **Z5230**, contains one set of bushings for one heater. To accommodate bushings,  $\frac{17}{32} \times \frac{11}{16}$  inch diameter mounting holes **must** be specified when ordering the heater.

## Extended Capabilities For 375 High-Temperature Strip Heaters

### Options

#### Tab Removal

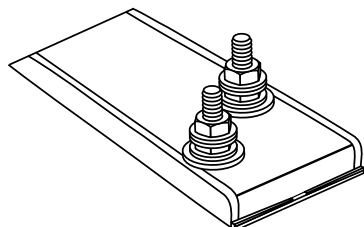

Tab removal is available from stock or manufactured products. Length without tabs equals total length including tabs minus 1 1/2 in. (38 mm).

#### Moisture Protection

##### Improved Insulation Resistance Value (IIRV)

**Treatment**—This process coats the MgO insulation. The treated insulation fends off moisture when unheated for long periods of time. It is also ideal for heaters that are exported to customers around the world, where high humidity may be a problem.

#### Ground Studs and Mounting Studs

Standard 1/4-20 x 1 1/2 in. (38 mm) or M6-1 x 40 steel studs are welded to the heater. Contact your Watlow representative for exact locations on specific heaters.

#### Flat Tabs

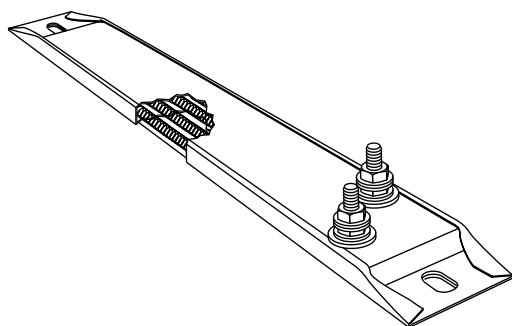

Mounting tabs can be formed flat to allow bar clamping.

# Strip/Clamp-On Heaters

## 375 High-Temperature Strip Heaters

### Heater Part Numbers

| Width<br>in. (mm) | Length<br>in. (mm) | Term.    | Volts | Power<br>(Watts) | Watt<br>Density<br>W/in <sup>2</sup> (W/cm <sup>2</sup> ) | Approx.<br>Net Wt.<br>lbs (kg) | Delivery | Part<br>Number | Chromalox® Part No. ①       |                       | Wellman® Part No. ①        |                       |
|-------------------|--------------------|----------|-------|------------------|---|--------------------------------|----------|----------------|-----------------------------|-----------------------|----------------------------|-----------------------|
|                   |                    |          |       |                  |   |                                |          |                | Rust Resist.<br>Iron Sheath | Chrome Stl.<br>Sheath | Aluminized<br>Steel Sheath | Chrome Stl.<br>Sheath |
| 1 1/2 (38)        | 5 1/2 (140)        | Parallel | 120   | 125              | 35 (5.4)  | 0.4 (0.18)                     | RS       | SGA1J5JP1      | PT-512                      | —                     | —                          | —                     |
|                   | 5 1/2 (140)        | Parallel | 120   | 250              | 70 (10.8)   | 0.4 (0.18)                     | RS       | SGA1J5JP2      | —                           | PT-502                | —                          | —                     |
|                   | 6 (152)            | Parallel | 120   | 150              | 35 (5.4)  | 0.4 (0.18)                     | RS       | SGA1J6AP2      | PT-615                      | —                     | —                          | —                     |
|                   | 6 (152)            | Parallel | 240   | 150              | 35 (5.4)  | 0.4 (0.18)                     | RS       | SGA1J6AP3      | PT-615                      | —                     | —                          | —                     |
|                   | 6 (152)            | Parallel | 120   | 300              | 70 (10.8)   | 0.4 (0.18)                     | RS       | SGA1J6AP4      | —                           | PT-603                | —                          | —                     |
|                   | 6 (152)            | Parallel | 240   | 300              | 70 (10.8)   | 0.4 (0.18)                     | RS       | SGA1J6AP5      | —                           | PT-603                | —                          | —                     |
|                   | 7 1/2 (191)        | Offset   | 120   | 150              | 29 (4.5)  | 0.5 (0.23)                     | RS       | SGA1J7JO1      | OT-715                      | —                     | SS1041                     | —                     |
|                   | 7 1/2 (191)        | Offset   | 240   | 150              | 29 (4.5)  | 0.5 (0.23)                     | M        | SGA1J7JO2      | OT-715                      | —                     | SS1052                     | —                     |
|                   | 7 1/2 (191)        | Offset   | 240   | 200              | 38 (5.9)  | 0.5 (0.23)                     | RS       | SGA1J7JO3      | —                           | OT-702                | —                          | SS2052                |
|                   | 8 (203)            | Offset   | 120   | 150              | 25 (3.9)  | 0.5 (0.23)                     | RS       | SGA1J8AO1      | OT-815                      | —                     | SS1061                     | —                     |
|                   | 8 (203)            | Offset   | 240   | 150              | 25 (3.9)  | 0.5 (0.23)                     | RS       | SGA1J8AO5      | OT-815                      | —                     | SS1072                     | —                     |
|                   | 8 (203)            | Offset   | 120   | 175              | 29 (4.5)  | 0.5 (0.23)                     | RS       | SGA1J8AO6      | OT-817                      | —                     | SS1081                     | —                     |
|                   | 8 (203)            | Offset   | 240   | 175              | 29 (4.5)  | 0.5 (0.23)                     | M        | SGA1J8AO7      | OT-817                      | —                     | SS1092                     | —                     |
|                   | 8 (203)            | Offset   | 120   | 250              | 42 (6.5)  | 0.5 (0.23)                     | RS       | SGA1J8AO2      | —                           | OT-802                | —                          | SS2061                |
|                   | 8 (203)            | Offset   | 240   | 250              | 42 (6.5)  | 0.5 (0.23)                     | RS       | SGA1J8AO8      | —                           | OT-802                | —                          | SS2072                |
|                   | 8 (203)            | Offset   | 120   | 400              | 67 (10.4)   | 0.5 (0.23)                     | RS       | SGA1J8AO9      | —                           | OT-804                | —                          | SS2081                |
|                   | 8 (203)            | Offset   | 240   | 400              | 67 (10.4)   | 0.5 (0.23)                     | RS       | SGA1J8AO10     | —                           | OT-804                | —                          | SS2092                |
|                   | 8 (203)            | Offset   | 120   | 500              | 83 (12.9)   | 0.5 (0.23)                     | RS       | SGA1J8AO3      | —                           | —                     | —                          | —                     |
|                   | 8 (203)            | Offset   | 240   | 500              | 83 (12.9)   | 0.5 (0.23)                     | RS       | SGA1J8AO4      | —                           | —                     | —                          | —                     |
|                   | 8 (203)            | 1-on-1   | 120   | 150              | 24 (3.7)  | 0.5 (0.23)                     | RS       | SGA1J8AT1      | S-815                       | —                     | SD1021                     | —                     |
|                   | 8 (203)            | 1-on-1   | 240   | 150              | 24 (3.7)  | 0.5 (0.23)                     | M        | SGA1J8AT2      | S-815                       | —                     | SD1032                     | —                     |
|                   | 9 1/2 (241)        | 1-on-1   | 120   | 200              | 23 (3.6)  | 0.6 (0.27)                     | M        | SGA1J9JT1      | S-920                       | —                     | SD1041                     | —                     |
|                   | 10 1/2 (267)       | Offset   | 120   | 250              | 26 (4.0)  | 0.7 (0.32)                     | RS       | SGA1J10JO1     | OT-1025                     | —                     | SS1101                     | —                     |
|                   | 10 1/2 (267)       | Offset   | 240   | 250              | 26 (4.0)  | 0.7 (0.32)                     | RS       | SGA1J10JO2     | OT-1025                     | —                     | SS1102                     | —                     |
|                   | 10 1/2 (267)       | Offset   | 120   | 350              | 36 (5.6)  | 0.7 (0.32)                     | RS       | SGA1J10JO8     | —                           | OT-1003               | —                          | SS2101                |
|                   | 10 1/2 (267)       | Offset   | 240   | 350              | 36 (5.6)  | 0.7 (0.32)                     | RS       | SGA1J10JO5     | —                           | OT-1003               | —                          | SS2112                |
|                   | 10 1/2 (267)       | Offset   | 120   | 400              | 41 (6.4)  | 0.7 (0.32)                     | RS       | SGA1J10JO6     | —                           | OT-1004               | —                          | SS2131                |
|                   | 10 1/2 (267)       | Offset   | 240   | 400              | 41 (6.4)  | 0.7 (0.32)                     | RS       | SGA1J10JO7     | —                           | OT-1004               | —                          | SS2132                |
|                   | 12 (305)           | Offset   | 120   | 250              | 21 (3.3)  | 0.8 (0.32)                     | RS       | SGA1J12AO1     | OT-1225                     | OT-1202               | SS1141                     | —                     |
|                   | 12 (305)           | Offset   | 240   | 250              | 21 (3.3)  | 0.8 (0.32)                     | RS       | SGA1J12AO2     | OT-1225                     | OT-1202               | SS1152                     | —                     |
|                   | 12 (305)           | Offset   | 120   | 350              | 29 (4.5)  | 0.8 (0.36)                     | RS       | SGA1J12AO5     | —                           | OT-1203               | —                          | SS2141                |
|                   | 12 (305)           | Offset   | 240   | 350              | 29 (4.5)  | 0.8 (0.36)                     | RS       | SGA1J12AO6     | —                           | OT-1203               | —                          | SS2152                |
|                   | 12 (305)           | Offset   | 120   | 500              | 42 (6.5)  | 0.8 (0.36)                     | RS       | SGA1J12AO3     | —                           | OT-1205               | —                          | SS2161                |
|                   | 12 (305)           | Offset   | 240   | 500              | 42 (6.5)  | 0.8 (0.36)                     | RS       | SGA1J12AO4     | —                           | OT-1205               | —                          | SS2172                |
|                   | 12 (305)           | 1-on-1   | 120   | 250              | 20 (3.1)  | 0.8 (0.36)                     | M        | SGA1J12AT1     | S-1225                      | S-1202                | SD1061                     | SD2071                |
|                   | 12 (305)           | 1-on-1   | 240   | 250              | 20 (3.1)  | 0.8 (0.36)                     | RS       | SGA1J12AT2     | S-1225                      | S-1202                | SD1072                     | SD2082                |
|                   | 12 (305)           | 1-on-1   | 240   | 500              | 40 (6.2)  | 0.8 (0.36)                     | RS       | SGA1J12AT3     | —                           | S-1205                | —                          | SD2122                |
|                   | 14 (356)           | Offset   | 120   | 300              | 20 (3.1)  | 0.9 (0.41)                     | RS       | SGA1J14AO2     | OT-1430                     | —                     | SS1181                     | —                     |
|                   | 14 (356)           | Offset   | 240   | 300              | 20 (3.1)  | 0.9 (0.41)                     | RS       | SGA1J14AO1     | OT-1430                     | —                     | SS1192                     | —                     |
|                   | 14 (356)           | Offset   | 120   | 500              | 33 (5.1)  | 0.9 (0.41)                     | RS       | SGA1J14AO3     | —                           | OT-1405               | —                          | SS2181                |
|                   | 14 (356)           | Offset   | 240   | 500              | 33 (5.1)  | 0.9 (0.41)                     | RS       | SGA1J14AO4     | —                           | OT-1405               | —                          | SS2192                |
|                   | 14 (356)           | 1-on-1   | 120   | 300              | 20 (3.1)  | 0.9 (0.41)                     | M        | SGA1J14AT1     | S-1430                      | —                     | SD1131                     | —                     |
|                   | 15 1/4 (387)       | Offset   | 120   | 325              | 19 (2.9)  | 1.0 (0.45)                     | M        | SGA1J15EO2     | OT-1532                     | —                     | SS1201                     | —                     |
|                   | 15 1/4 (387)       | Offset   | 240   | 325              | 19 (2.9)  | 1.0 (0.45)                     | M        | SGA1J15EO3     | OT-1532                     | —                     | SS1212                     | —                     |
|                   | 15 1/4 (387)       | Offset   | 240   | 500              | 30 (4.6)  | 1.0 (0.45)                     | RS       | SGA1J15EO4     | —                           | OT-1505               | —                          | SS2212                |

CONTINUED

①Chromalox® and Wellman® part numbers are used as a cross reference to help select the equivalent Watlow part number. Chromalox® sizes 27 in. (686 mm) and longer, and all Wellman® sizes have mounting slot center to center distances 1/8 in. (3.2 mm) less than Watlow spacing.

**RAPID SHIP**

- RS - Next day shipment
- M - Manufacturing lead times

# Strip/Clamp-On Heaters

## 375 High-Temperature Strip Heaters

### Heater Part Numbers (Continued)

| Width<br>in. (mm) | Length<br>in. (mm) | Term.  | Volts | Power<br>(Watts) | Watt<br>Density<br>W/in <sup>2</sup> (W/cm <sup>2</sup> ) | Approx.<br>Net Wt.<br>lbs (kg) | Delivery | Part<br>Number | Chromalox® Part No. ①       |                       | Wellman® Part No. ①        |                       |
|-------------------|--------------------|--------|-------|------------------|---|--------------------------------|----------|----------------|-----------------------------|-----------------------|----------------------------|-----------------------|
|                   |                    |        |       |                  |   |                                |          |                | Rust Resist.<br>Iron Sheath | Chrome Stl.<br>Sheath | Aluminized<br>Steel Sheath | Chrome Stl.<br>Sheath |
| 1 1/2 (38)        | 17 7/8 (454)       | Offset | 120   | 350              | 17 (2.6)  | 1.2 (0.54)                     | RS       | SGA1J17RO4     | OT-1835                     | —                     | SS1221                     | SS2221                |
|                   | 17 7/8 (454)       | Offset | 240   | 350              | 17 (2.6)  | 1.2 (0.54)                     | M        | SGA1J17RO5     | OT-1835                     | —                     | SS1232                     | SS2232                |
|                   | 17 7/8 (454)       | Offset | 120   | 375              | 18 (2.8)  | 1.2 (0.54)                     | RS       | SGA1J17RO6     | OT-1837                     | —SS1261               | SS2241                     | —                     |
|                   | 17 7/8 (454)       | Offset | 240   | 375              | 18 (2.8)  | 1.2 (0.54)                     | M        | SGA1J17RO7     | OT-1837                     | —                     | SS1252                     | —                     |
|                   | 17 7/8 (454)       | Offset | 120   | 500              | 24 (3.7)  | 1.2 (0.54)                     | RS       | SGA1J17RO1     | OT-1850                     | —                     | SS1261                     | SS2241                |
|                   | 17 7/8 (454)       | Offset | 240   | 500              | 24 (3.7)  | 1.2 (0.54)                     | RS       | SGA1J17RO2     | OT-1850                     | —                     | SS1272                     | SS2252                |
|                   | 17 7/8 (454)       | Offset | 120   | 750              | 36 (5.6)  | 1.2 (0.54)                     | RS       | SGA1J17RO9     | —                           | OT-1807               | — SS2261                   | —                     |
|                   | 17 7/8 (454)       | Offset | 240   | 750              | 36 (5.6)  | 1.2 (0.54)                     | RS       | SGA1J17RO8     | —                           | OT-1807               | — SS2272                   | —                     |
|                   | 17 7/8 (454)       | Offset | 120   | 1000             | 48 (7.4)  | 1.2 (0.54)                     | RS       | SGA1J17RO10    | —                           | OT-1801               | — SS2281                   | —                     |
|                   | 17 7/8 (454)       | Offset | 240   | 1000             | 48 (7.4)  | 1.2 (0.54)                     | RS       | SGA1J17RO3     | —                           | OT-1801               | — SS2292                   | —                     |
|                   | 17 7/8 (454)       | 1-on-1 | 120   | 500              | 24 (3.7)  | 1.2 (0.54)                     | M        | SGA1J17RT1     | S-1850                      | S-1805                | SD1211                     | SD2171                |
|                   | 17 7/8 (454)       | 1-on-1 | 240   | 500              | 24 (3.7)  | 1.2 (0.54)                     | RS       | SGA1J17RT2     | S-1850                      | S-1805                | SD1222                     | SD2182                |
|                   | 17 7/8 (454)       | 1-on-1 | 240   | 750              | 35 (5.4)  | 1.2 (0.54)                     | M        | SGA1J17RT3     | —                           | S-1807                | — SD2202                   | —                     |
|                   | 17 7/8 (454)       | 1-on-1 | 120   | 1000             | 47 (7.3)  | 1.2 (0.54)                     | M        | SGA1J17RT4     | —                           | S-1801                | — SD2211                   | —                     |
|                   | 17 7/8 (454)       | 1-on-1 | 240   | 1000             | 47 (7.3)  | 1.2 (0.54)                     | M        | SGA1J17RT5     | —                           | S-1801                | — SD2222                   | —                     |
|                   | 19 1/2 (496)       | Offset | 240   | 350              | 15 (2.3)  | 1.3 (0.59)                     | M        | SGA1J19JO6     | OT-1935                     | —                     | SS1301                     | —                     |
|                   | 19 1/2 (496)       | Offset | 120   | 500              | 22 (3.4)  | 1.3 (0.59)                     | M        | SGA1J19JO7     | OT-1950                     | OT-1905               | — SS2301                   | —                     |
|                   | 19 1/2 (496)       | Offset | 240   | 500              | 22 (3.4)  | 1.3 (0.59)                     | RS       | SGA1J19JO4     | OT-1950                     | OT-1905               | — SS2312                   | —                     |
|                   | 19 1/2 (496)       | Offset | 240   | 750              | 32 (5.0)  | 1.3 (0.59)                     | RS       | SGA1J19JO8     | —                           | OT-1907               | — —                        | —                     |
|                   | 19 1/2 (496)       | Offset | 240   | 1000             | 43 (6.7)  | 1.3 (0.59)                     | RS       | SGA1J19JO1     | —                           | OT-1901               | — SS2332                   | —                     |
|                   | 19 1/2 (496)       | 1-on-1 | 240   | 750              | 32 (5.0)  | 1.3 (0.59)                     | M        | SGA1J19JT1     | —                           | S-1907                | — SD2262                   | —                     |
|                   | 21 (533)           | Offset | 120   | 500              | 20 (3.1)  | 1.4 (0.64)                     | M        | SGA1J21AO1     | OT-2150                     | —                     | SS1341                     | —                     |
|                   | 21 (533)           | Offset | 240   | 500              | 20 (3.1)  | 1.4 (0.64)                     | RS       | SGA1J21AO2     | OT-2150                     | —                     | SS1352                     | —                     |
|                   | 21 (533)           | Offset | 120   | 750              | 29 (4.5)  | 1.4 (0.64)                     | M        | SGA1J21AO3     | —                           | OT-2107               | — SS2341                   | —                     |
|                   | 21 (533)           | Offset | 240   | 750              | 29 (4.5)  | 1.4 (0.64)                     | RS       | SGA1J21AO4     | —                           | OT-2107               | — SS2352                   | —                     |
|                   | 21 (533)           | 1-on-1 | 120   | 500              | 19 (2.9)  | 1.4 (0.64)                     | M        | SGA1J21AT1     | S-2050                      | S-2005                | SD1291                     | SD2291                |
|                   | 23 3/4 (603)       | Offset | 120   | 500              | 17 (2.6)  | 1.5 (0.68)                     | RS       | SGA1J23NO5     | OT-2450                     | OT-2405               | SS1361                     | SS2361                |
|                   | 23 3/4 (603)       | Offset | 240   | 500              | 17 (2.6)  | 1.5 (0.68)                     | RS       | SGA1J23NO6     | OT-2450                     | OT-2405               | SS1372                     | SS2372                |
|                   | 23 3/4 (603)       | Offset | 120   | 750              | 25 (3.9)  | 1.5 (0.68)                     | M        | SGA1J23NO1     | OT-2475                     | OT-2407               | SS1391                     | SS2381                |
|                   | 23 3/4 (603)       | Offset | 240   | 750              | 25 (3.9)  | 1.5 (0.68)                     | RS       | SGA1J23NO2     | OT-2475                     | OT-2407               | SS1402                     | SS2392                |
|                   | 23 3/4 (603)       | Offset | 120   | 1000             | 34 (5.3)  | 1.5 (0.68)                     | RS       | SGA1J23NO7     | —                           | OT-2401               | — SS2401                   | —                     |
|                   | 23 3/4 (603)       | Offset | 240   | 1000             | 34 (5.3)  | 1.5 (0.68)                     | RS       | SGA1J23NO3     | —                           | OT-2401               | — SS2412                   | —                     |
|                   | 23 3/4 (603)       | Offset | 240   | 1500             | 51 (7.9)  | 1.5 (0.68)                     | RS       | SGA1J23NO4     | —                           | OT-2415               | — —                        | —                     |
|                   | 23 3/4 (603)       | 1-on-1 | 240   | 250              | 8 (1.2)   | 1.5 (0.68)                     | M        | SGA1J23NT1     | S-2425                      | —                     | SD1322                     | —                     |
|                   | 23 3/4 (603)       | 1-on-1 | 240   | 500              | 17 (2.6)  | 1.5 (0.68)                     | M        | SGA1J23NT3     | S-2450                      | S-2404                | SD1342                     | SD2322                |
|                   | 23 3/4 (603)       | 1-on-1 | 240   | 750              | 25 (3.9)  | 1.5 (0.68)                     | RS       | SGA1J23NT5     | —                           | S-2407                | — SD2352                   | —                     |
|                   | 23 3/4 (603)       | 1-on-1 | 120   | 1000             | 33 (5.1)  | 1.5 (0.68)                     | M        | SGA1J23NT6     | —                           | S-2401                | — SD2361                   | —                     |
|                   | 23 3/4 (603)       | 1-on-1 | 240   | 1000             | 33 (5.1)  | 1.5 (0.68)                     | M        | SGA1J23NT7     | —                           | S-2401                | — SD2372                   | —                     |
|                   | 23 3/4 (603)       | 1-on-1 | 240   | 1500             | 50 (7.8)  | 1.5 (0.68)                     | M        | SGA1J23NT8     | —                           | S-2415                | — —                        | —                     |
|                   | 25 1/2 (648)       | Offset | 120   | 500              | 16 (2.5)  | 1.7 (0.77)                     | RS       | SGA1J25JO1     | OT-2550                     | —                     | SS1421                     | —                     |
|                   | 25 1/2 (648)       | Offset | 240   | 500              | 16 (2.5)  | 1.7 (0.77)                     | RS       | SGA1J25JO2     | OT-2550                     | —                     | SS1432                     | —                     |
|                   | 25 1/2 (648)       | Offset | 120   | 750              | 23 (3.6)  | 1.7 (0.77)                     | M        | SGA1J25JO3     | OT-2575                     | OT2507                | SS1441                     | SS2421                |
|                   | 25 1/2 (648)       | Offset | 240   | 750              | 23 (3.6)  | 1.7 (0.77)                     | RS       | SGA1J25JO4     | OT-2575                     | OT-2507               | SS1452                     | SS2432                |
|                   | 25 1/2 (648)       | Offset | 240   | 1000             | 31 (4.8)  | 1.7 (0.77)                     | RS       | SGA1J25JO5     | —                           | OT-2501               | — SS2452                   | —                     |

CONTINUED

①Chromalox® and Wellman® part numbers are used as a cross reference to help select the equivalent Watlow part number. Chromalox® sizes 27 in. (686 mm) and longer, and all Wellman® sizes have mounting slot center to center distances 1/8 in. (3.2 mm) less than Watlow spacing.

**RAPID SHIP**

- RS - Next day shipment
- M - Manufacturing lead times

# Strip/Clamp-On Heaters

## 375 High-Temperature Strip Heaters

### Heater Part Numbers (Continued)

| Width<br>in. (mm) | Length<br>in. (mm) | Term.  | Volts | Power<br>(Watts) | Watt<br>Density<br>W/in <sup>2</sup> (W/cm <sup>2</sup> ) | Approx.<br>Net Wt.<br>lbs (kg) | Delivery | Part<br>Number    | Chromalox® Part No. ①       |                       | Wellman® Part No. ①        |                       |
|-------------------|--------------------|--------|-------|------------------|---|--------------------------------|----------|-------------------|-----------------------------|-----------------------|----------------------------|-----------------------|
|                   |                    |        |       |                  |   |                                |          |                   | Rust Resist.<br>Iron Sheath | Chrome Stl.<br>Sheath | Aluminized<br>Steel Sheath | Chrome Stl.<br>Sheath |
| 1 1/2 (38)        | 26 3/4 (680)       | Offset | 240   | 700              | 21 (3.3)  | 1.7 (0.77)                     | RS       | <b>SGA1J26NO1</b> | OT-2670                     | —                     | SS1472                     | —                     |
|                   | 26 3/4 (680)       | Offset | 240   | 1000             | 29 (4.5)  | 1.7 (0.77)                     | RS       | <b>SGA1J26NO2</b> | —                           | OT-2601               | —                          | SS2472                |
|                   | 30 1/2 (775)       | Offset | 120   | 750              | 19 (2.9)  | 2.0 (0.91)                     | M        | <b>SGA1J30JO2</b> | OT-3075                     | OT-3007               | SS1481                     | —                     |
|                   | 30 1/2 (775)       | Offset | 240   | 750              | 19 (2.9)  | 2.0 (0.91)                     | RS       | <b>SGA1J30JO3</b> | OT-3075                     | OT-3007               | SS1492                     | SS2482                |
|                   | 30 1/2 (775)       | 1-on-1 | 240   | 750              | 19 (2.9)  | 2.0 (0.91)                     | RS       | <b>SGA1J30JT1</b> | S-3075                      | S-3007                | SD1452                     | —                     |
|                   | 33 1/2 (851)       | Offset | 240   | 750              | 17 (2.6)  | 2.2 (1.0)                      | RS       | <b>SGA1J33JO1</b> | OT-3375                     | OT-3307               | SS1522                     | SS2522                |
|                   | 33 1/2 (851)       | 1-on-1 | 240   | 1000             | 22 (3.4)  | 2.2 (1.0)                      | M        | <b>SGA1J33JT1</b> | —                           | S-3301                | —                          | SD2472                |
|                   | 35 7/8 (911)       | Offset | 120   | 1000             | 21 (3.3)  | 2.3 (1.0)                      | M        | <b>SGA1J35RO4</b> | OT-3610                     | —                     | SS1531                     | —                     |
|                   | 35 7/8 (911)       | Offset | 240   | 1000             | 21 (3.3)  | 2.3 (1.0)                      | RS       | <b>SGA1J35RO3</b> | OT-3610                     | —                     | SS1542                     | SS2532                |
|                   | 35 7/8 (911)       | Offset | 240   | 1500             | 31 (4.8)  | 2.3 (1.0)                      | RS       | <b>SGA1J35RO1</b> | —                           | OT-3601               | SS2552                     | —                     |
|                   | 35 7/8 (911)       | 1-on-1 | 240   | 1000             | 21 (3.3)  | 2.3 (1.0)                      | RS       | <b>SGA1J35RT1</b> | S-3610                      | S-3601                | SD1492                     | SD2492                |
|                   | 38 1/2 (978)       | Offset | 120   | 1000             | 19 (2.9)  | 2.5 (1.1)                      | M        | <b>SGA1J38JO2</b> | OT-3810                     | OT-3801               | SS1581                     | SS2561                |
|                   | 38 1/2 (978)       | Offset | 240   | 1500             | 29 (4.5)  | 2.5 (1.1)                      | RS       | <b>SGA1J38JO3</b> | —                           | OT-3815               | —                          | —                     |
|                   | 42 1/2 (1080)      | Offset | 240   | 1500             | 26 (4.0)  | 2.8 (1.3)                      | RS       | <b>SGA1J42JO1</b> | —                           | OT-4315               | SS1632                     | SS2632                |
|                   | 47 7/8 (1216)      | Offset | 240   | 2250             | 34 (5.3)  | 3.1 (1.4)                      | RS       | <b>SGA1J47RO1</b> | —                           | OT-4822               | —                          | —                     |

①Chromalox® and Wellman® part numbers are used as a cross reference to help select the equivalent Watlow part number. Chromalox® sizes 27 in. (686 mm) and longer, and all Wellman® sizes have mounting slot center to center distances 1/8 in. (3.2 mm) less than Watlow spacing.

**Note:** 5/16 in. x 1/2 in. (7.9 mm x 13 mm) mounting slots are supplied on all 375 strip heaters. Note that the Watlow part number specifies that the 375 strip heater includes an aluminized steel sheath. If a special sheath material is required, such as stainless steel, please contact your Watlow representative for material availability.

**RAPID SHIP**

- **RS** - Next day shipment
- **M** - Manufacturing lead times

# Strip/Clamp-On Heaters

## FIREBAR® Clamp-On Heaters

FIREBAR® heating elements provide added heating performance over standard round tubular heating elements—especially for immersion applications in petroleum based liquids requiring high kilowatts.

The FIREBAR's unique flat surface geometry packs more power in shorter elements and assemblies, along with a host of other performance improvements. These include:

- Minimizing coking and fluid degrading
- Enhancing the flow of fluid past the element's surface to carry heat from the sheath
- Improving heat transfer with a significantly larger boundary layer allowing much more liquid to flow up and across the sheath's surface

FIREBAR elements are available in single- and double-ended constructions with one inch or  $\frac{5}{8}$  inch heights. These two configuration variables make it possible to use FIREBAR elements instead of round tubular elements in virtually all applications.

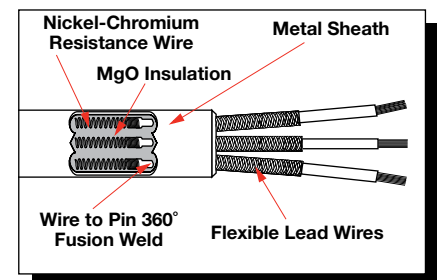
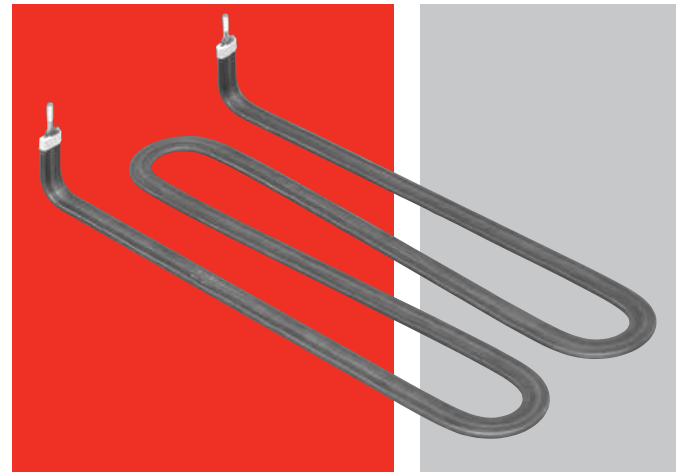

One-Inch Double-Ended FIREBAR Element and Lead Configurations

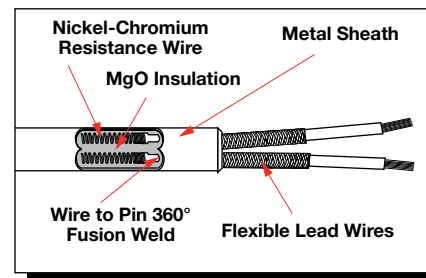

$\frac{5}{8}$ -Inch Double-Ended FIREBAR Element and Lead Configurations

**For detailed product and technical data,  
see the full FIREBAR product  
section located on pages 93 through 111.**

# Strip/Clamp-On Heaters

## Thick Film Conduction Heaters

The Watlow 430 stainless steel thick film conduction heater is ideal for many applications where fast response and uniformity are essential. A clamp-on, thick film heater provides the best possible combination of heat transfer, thermal efficiency, temperature response and uniformity in a low profile package.

This high-performance heater can be used in areas where space is limited or where conventional heaters cannot be used due to limited voltage and wattage combinations.

Thick film conduction heaters provide a low profile in a variety of shapes including two-dimensional circular and rectangular forms. Direct contact of thick film heaters to surfaces ensures efficient heat transfer through thermally stable substrates and precise resistance trace patterns.

### Performance Capabilities

- Maximum substrate temperature up to 1022°F (550°C). Contact your Watlow representative for applications over 842°F (450°C)
- Watt densities up to 75 W/in<sup>2</sup> (11.6 W/cm<sup>2</sup>)
- Voltages up to 240V

### Features and Benefits

#### Watt densities up to 75 W/in<sup>2</sup> (11.6 W/cm<sup>2</sup>) for clamp-on applications

- Allows precise, repeatable wattage distribution and uniform temperature profile

#### Threaded stud termination

- Produces strong, trouble-free connections, see *Termination Assembly* drawing on page 464

#### Agency approvals

- UL® component recognition available upon request

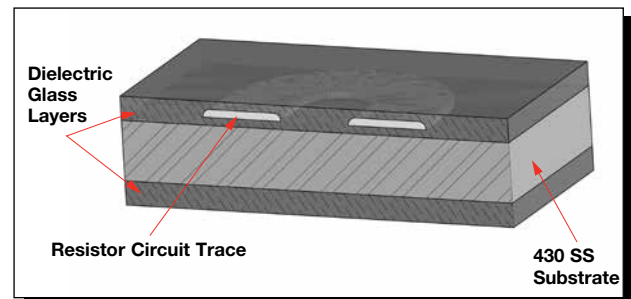
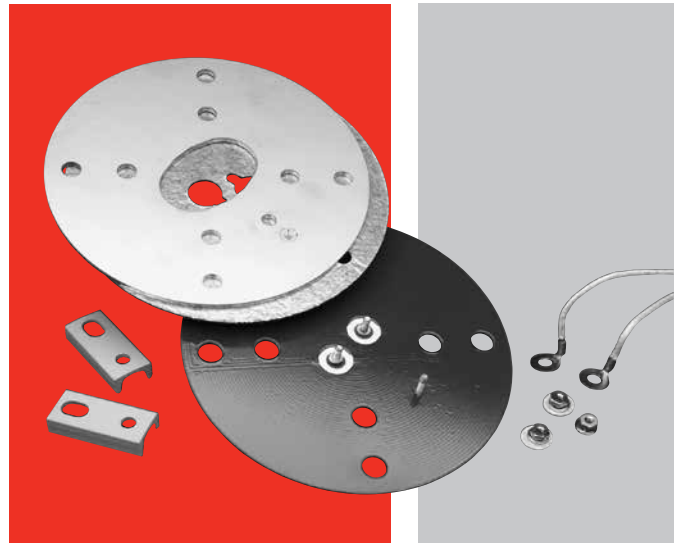

### Typical Applications

- Food warming cabinets
- Load dump resistors
- Seal bars
- Deposition chamber lids

**For detailed product and technical data,  
see the full Thick Film Conduction  
product section located on pages 463 through 466.**